



PCD

TP CD2 208

TUNIT
PCD

Svasatore 2 taglienti
Deburr 2 flutes
 Outil pour ébavurer 2 lèvres
Entgrater 2 Schneiden

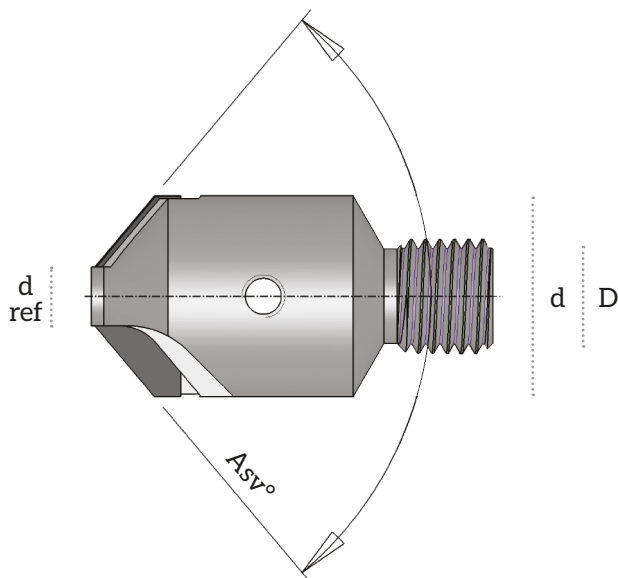

d	d ref	D	ASV°	PCD
10.00	2.50	M6X1,0	100°/130°	TPCD2 208-1000
12.00	3.00	M6X1,0	100°/130°	TPCD2 208-1200
14.00	3.00	M6X1,0	100°/130°	TPCD2 208-1400
16.00	4.00	M6X1,0	100°/130°	TPCD2 208-1600

Angolo dell'elica: 0° | *Helix angle: 0°* | Angle d'hélice: 0° | *Spiralwinkel: 0°*
 Equilibratura: G 2,5 < 1 gr/mm | *Balance: G 2,5 < 1 gr/mm* | Équilibrage: G 2,5 < 1 gr/mm | *Auswuchten: G 2,5 < 1 gr/mm*



scheda tecnica
technical data sheet
 données techniques
Technisches Datenblatt

Esecuzione speciale | *diametri intermedi*
Out of range | other sizes
 Exécution spéciale | *diamètres intermédiaires*
Sonderausführungen | Zwischenabmessungen

Su richiesta
On request
 Sur demande
Auf Anfrage

Applicazioni
Application groups
 Groupe d'emploi
Anwendungsgruppen

